

SOFC

Submarine Power Cable

Submarine Optical-Fiber Composite Power Cable



ZHONGTIAN TECHNOLOGIES CO., LTD

ZTT

ZHONGTIAN TECHNOLOGIES SUBMARINE CABLE CO., LTD

## Brief Introduction



Zhongtian Technologies Submarine Cable Co., Ltd. is a subsidiary of nation-important-tech enterprise —Zhongtian Technologies Co., Ltd (Stock Number: 600522).

Located at the north of Yantze River, Jiangsu Nantong Port Development Zone, Zhongtian technologies Submarine Cable is specialized in Submarine Optical Fiber Cable, Submarine Power Cable, Submarine Optical Compound Power Cable, Low/Mid Voltage Cross Linking Cable, XLPE

Insulated Power cable and Accessories.

The developing of our nation's submarine cable industry is of far reaching importance and social benefits. It is not only the carrier of promoting the global informational development, but also the guarantee of ocean investigation and national sea power. The complicated ocean environment requires waterpressure resistance, abrasion resistance, high strength, rust resistance, long length submarine cables, whose production technique is quite difficult.

ZTT has the core technique and invention patent of producing submarine cables, whose products passed the state verification. Zhongtian Technologies Submarine cable has established a whole production line of manufacturing optical unit, stranding copper conductor, armoring steel tape/wire, cabling, stranding 24drums & argon-arc welding, jacking, with a dock of 5000 tonnages, we reached a 5000 kilometers of ability in producing, storing and delivering cables in one year.

Zhongtian technologies Submarine cable established its leading status by its special location, hydrographical condition, high-class manufacturing and testing equipments, professional technologies, flawless ensurence system, adequate and systematic service.

Zhongtian Technologies Submarine Cable Co., Ltd.---Developing with China's Ocean Economy!

Zhongtian Technologies Submarine Cable Co., Ltd.---Extending with China's Ean Power.



# Certification



# Core Technology Certificates

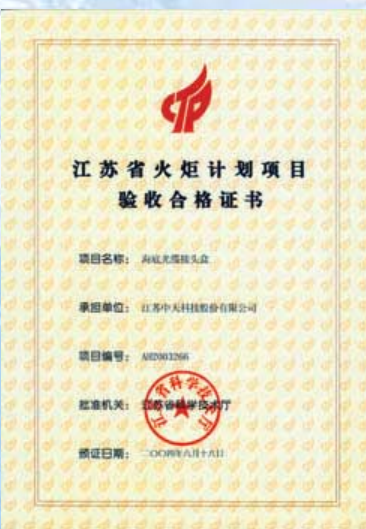
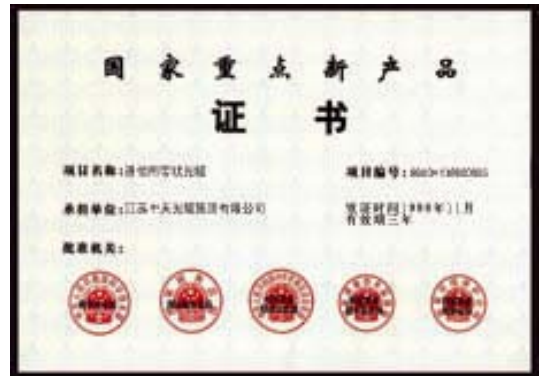

## Equipment



Outdoor of the factory building



Production line for fiber composite SUS-tube unit



Cross linking product line



Shock test of SOFC



Lead extruder



Partial discharge testing system



Insulating jacket & steel wire armoring product line



Cable storage ponds

## Fiber unit design

### The features of fiber unit

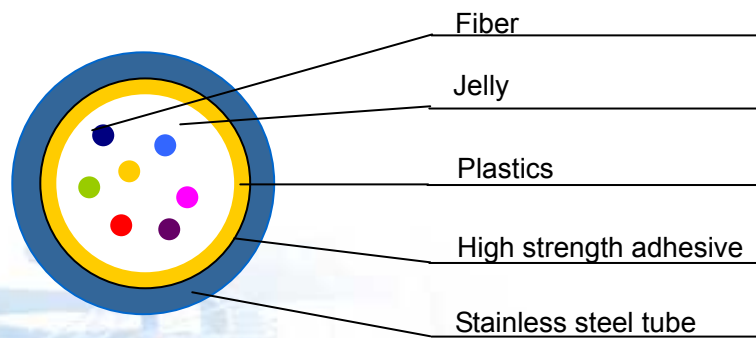

### Fiber unit

- Combination of conventional secondary coating process with advanced stainless steel tube laser welding process-forming a self-owned interllecture property
- Composite stainless steel tube-protecting fibers from damage caused by the sharp edges of the welding seam
- The inner wall of the steel tube and the outer wall of the plastic tube being adhered and sealed-providing good consistence and being resistance
- On-line excess length control technique-effectively controlling fiber excess length in the cable.

## Specifications

### Applied standards

Zhongtian Technologies SOFC follows with the specifications of the National Standards GB/T 18480-2001 Submarine Fiber Optic Cable and the National Military Standards GJB 4489-2002 General Specification for Submarine Fiber Optic Cable.

### Specifications

Parameter	Requirement
Tensile strength	For short-time tensile load, fiber strain $\leq$ 0.15%, fiber excess loss $\leq$ 0.05dB; For operation tensile load, fiber strain $\leq$ 0.15%, fiber excess loss $\leq$ 0.05dB.
Crush resistance	At pressure of 40kN/100mm, sustaining for 3 min, the pressure being applied at different points separated by 0.5m with each other, the fiber excess loss $\leq$ 0.05dB during and after the test.
Shock resistance	A 100kg of weight from the height of 390mm, dropping on five points separated by 500mm once for each point, the fiber excess loss $\leq$ 0.05dB during and after the test.
Bend cycling	Bending radius 1.0m, bending 30 times, weight 1000N, the fiber excess loss $\leq$ 0.5dB during and after the test.
Electrical performance	At DC 500V between stainless steel tube and ground, the resistance $\geq$ 10000M $\Omega$ .km, at DC 5000V between stainless tube and ground, without breakdown for 3 min.
Temperature cycling	-10 $^{\circ}$ C $\sim$ +40 $^{\circ}$ C (operation)
Waterblocking performance	After 14 days for 1250m of SOFC and 5.0MPa of water pressure, the longitudinal penetration length not more than 200m.

## Typical structure of shallow sea cable

### Single armored central tube type

#### Product Type:

**SOFCADK—/4~48SM**

Composite stainless steel tube optical fiber unit, PDPE inner sheath, medium carbon steel wire armor, Bitumen coating, polypropylene yarn wrapping covering

#### Structure

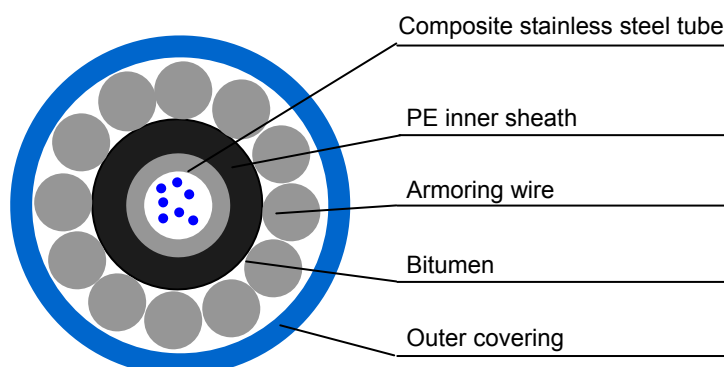

### Double armored central tube type

#### Product Type:

**SOFC---ASK/4~96SM**

Composite stainless steel tube optical fiber unit, PDPE inner sheath, medium carbon steel wire armor, Bitumen coating, polypropylene yarn wrapping covering.

#### Structure

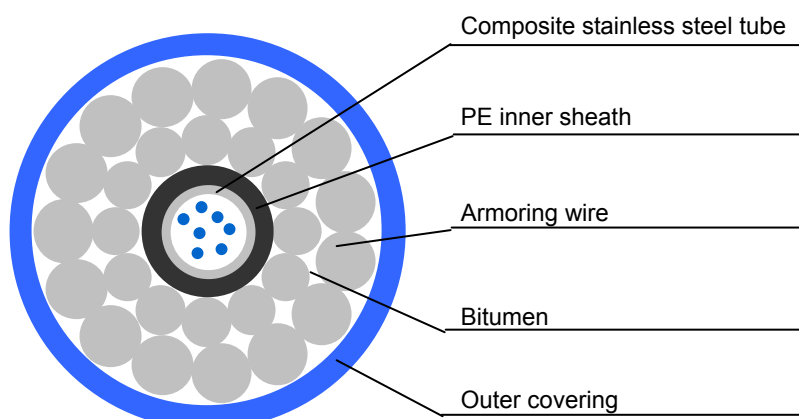

## Typical structure of shallow sea cable

### Double armored central tube type with power feeding

#### Product Type:

SOFC---BSK/4~96SM+8×1.6

Composite stainless steel tube stranding , HDPE inner sheath, medium carbon steel wire armor, Bitumen coating, polypropylene yarn wrapping covering.



#### Structure

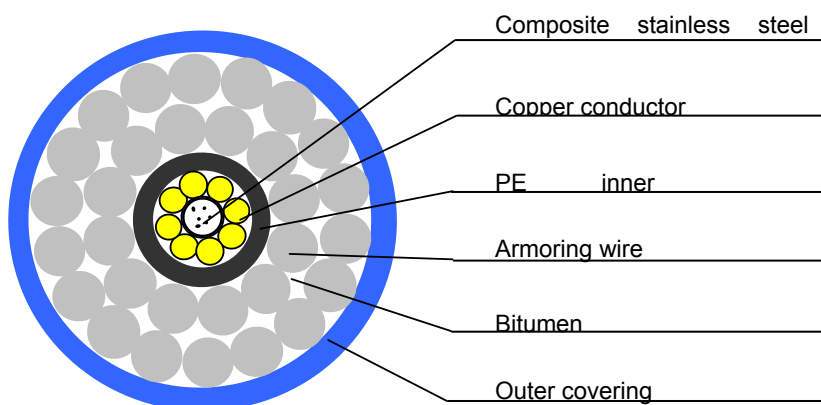

### Double armored layer stranded type

#### Product Type:

SOFC---CSK/48~288M

Composite stainless steel tube stranding , HDPE inner sheath, medium carbon steel wire armor, Bitumen coating, polypropylene yarn wrapping covering.



#### Structure

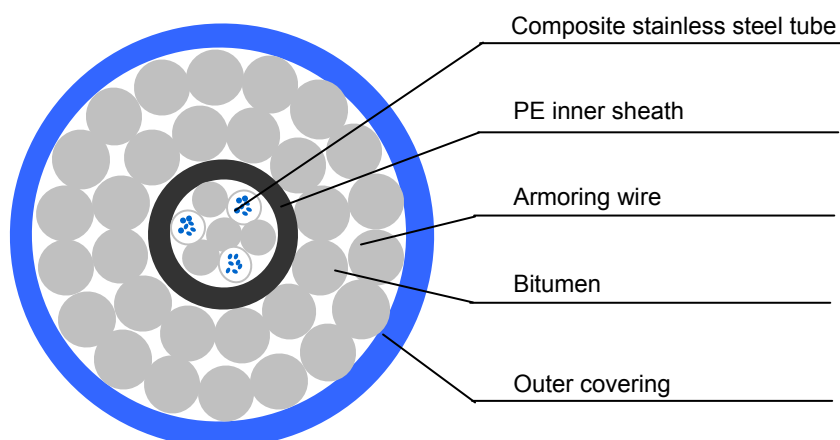

## Typical structure of deep sea cable

### Central bundle tube with single armored single armored inside type

SOFC---LWDK/4~24SM

Composite stainless steel tube fiber tube unit, High strength steel wire armored inside, Hermetically metallic sealed, HDPE sheath.

#### Structure

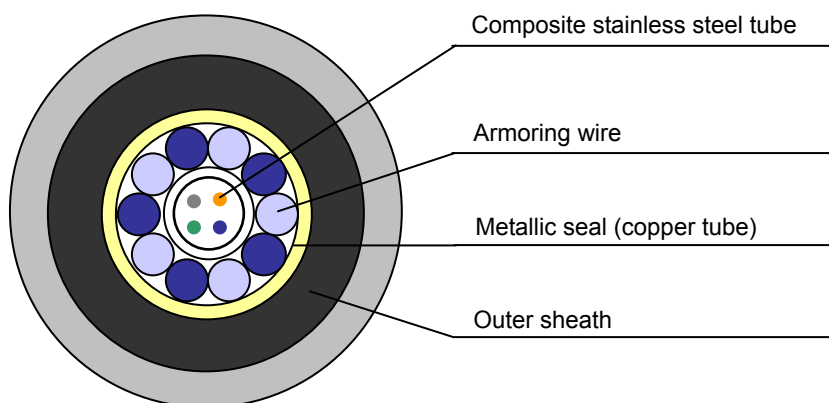

### Central bundle tube with double armored inside type

SOFC---LWSK/4~24SM

Composite stainless steel tube, High strength waney steel wire armored (tight -fit-type), Hermetically metallic sealed, HDPE sheath.

#### Structure

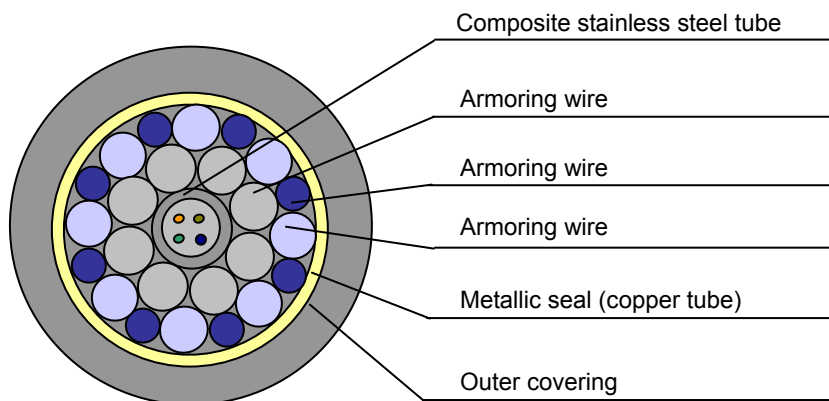

## Typical Specifications

Type	DK1	DK2	DK3	SK1	SK2	SK3	SK4	SK5	
Outer diameter	24	25	29	30	32	37	35	39	
Weight	In air	1.3	1.4	1.9	2.2	3.4	4.0	3.7	4.5
	In seawater	0.8	0.9	1.2	1.6	2.5	2.9	2.7	3.4
Breakage tensile strength	100	160	180	290	350	400	5000	600	
Short-time tensile Load	65	100	120	185	220	250	320	400	
Oper. Tensile Load	40	60	70	110	135	150	200	240	
Min. bending radius	0.7	0.8	0.9	0.9	1.0	1.1	1.1	1.2	
Crush resistance	20	20	20	40	40	40	40	40	
Shock resistance	133	133	133	266	266	266	266	266	

### Note:

1. The above is for reference only.
2. Zhongtian Technologies can produce various SOFCs which meet the requirements of customers, such as specific sea depth and sea conditions.

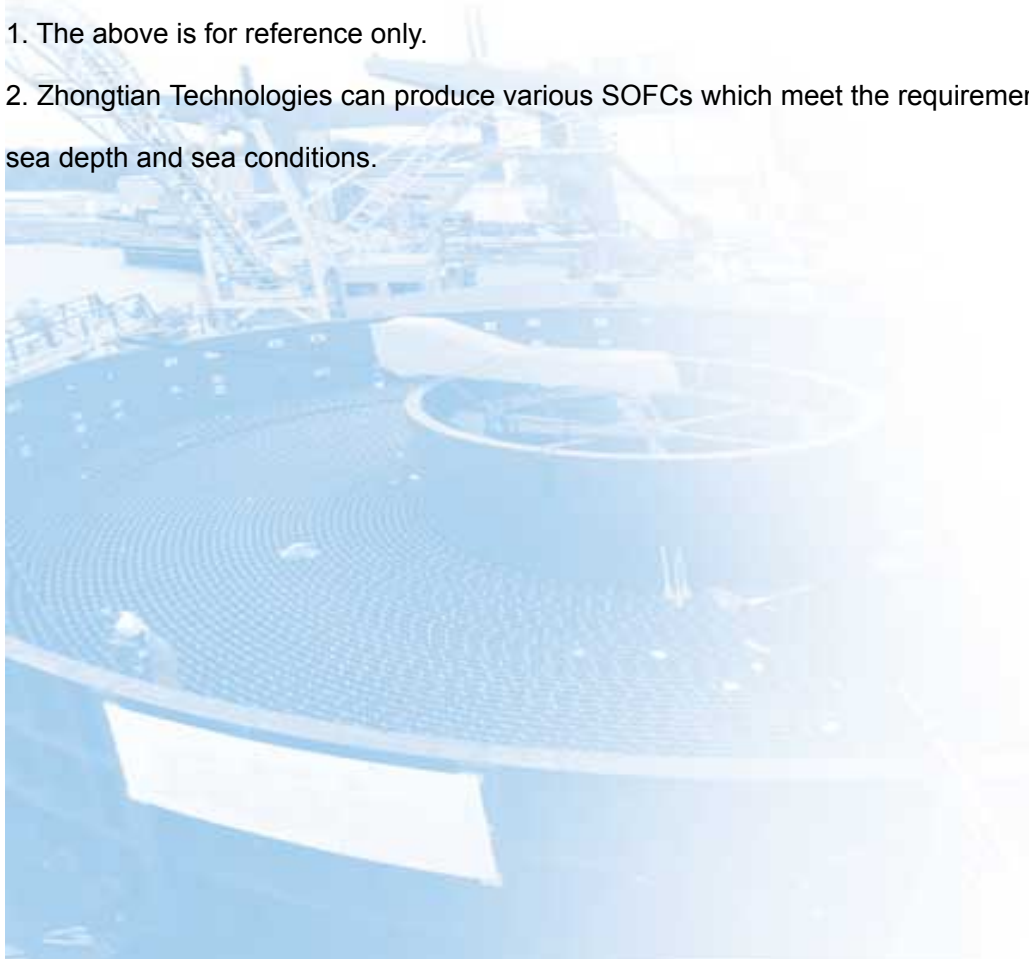

## Zhongtian Submarine Power Cable, Submarine Optical Fiber Compound Power cable

### Technical requirement

The products meet the state standard GB/T12706-2002 Rated voltage 1kV-35kV extruded insulated power cable and accessories and IEC 60502:1997 Rated voltage 1kV-35kV extruded insulated power cable and accessories.

Comparing with the electric power cable on land, the products have the same electrical performance. The products meet the special mechanical requirement in the sea. Optical performance of submarine fiber composite power cable is the same as that of submarine fiber optic cable.

### Type, name and application environment

Type	Name	Application environment
ZS-YJA41 ZS-YJAF41	Copper conductor XLPE insulated LAP sheathed or separately LAP sheathed alloy coated steel-wire armored fiber serving submarine power cable.	Used in seabed, platform and underwater, it able to bear external machine force or much tension.
ZS-YJQ41 ZS-YJQF41	Copper conductor XLPE insulated lead sheathed or separately lead sheathed thick steel-wire armored fiber covering submarine power cable	Used in seabed, platform and underwater, it able to bear external machine force or much tension.
ZS-YJA41+OFC ZS-YJAF41+OFC	Copper conductor XLPE insulated LAP sheathed or separately LAP sheathed alloy coated steel-wire armored fiber serving submarine optical fiber/electric power composite cable.	Used in seabed, platform and underwater, it able to bear external machine force or much tension.
ZS-YJQ41+OFC ZS-YJQF41+OFC	Copper conductor XLPE insulated lead sheathed or separately lead sheathed thick steel-wire armored fiber covering submarine optical fiber/electric power composite cable	Used in submarine, it able to bear external machine force or much tension.

# Typical structure of deep sea cable

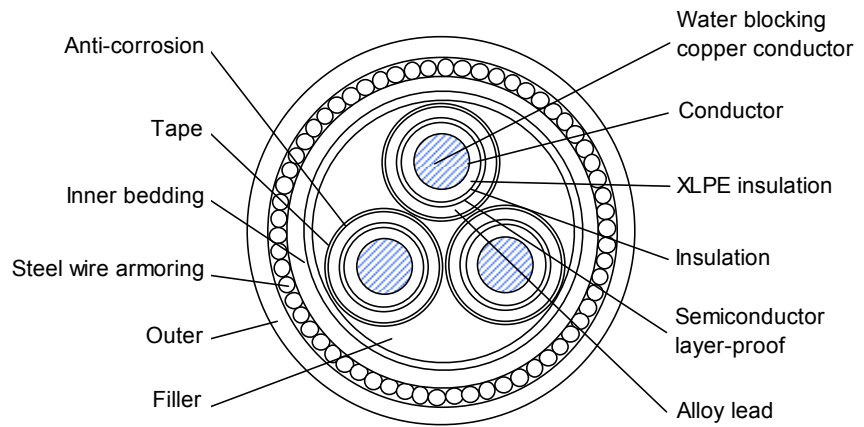

XLPE insulated separately lead sheath steel armored fiber covering submarine power cable

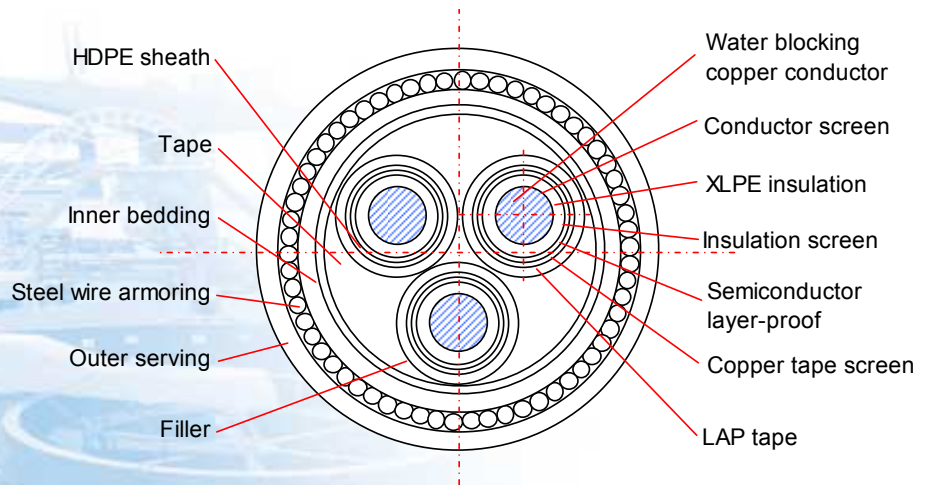

XLPE insulated separately lead sheath steel armored fiber covering submarine power cable

# Submarine Optical fiber Compound Power Cable

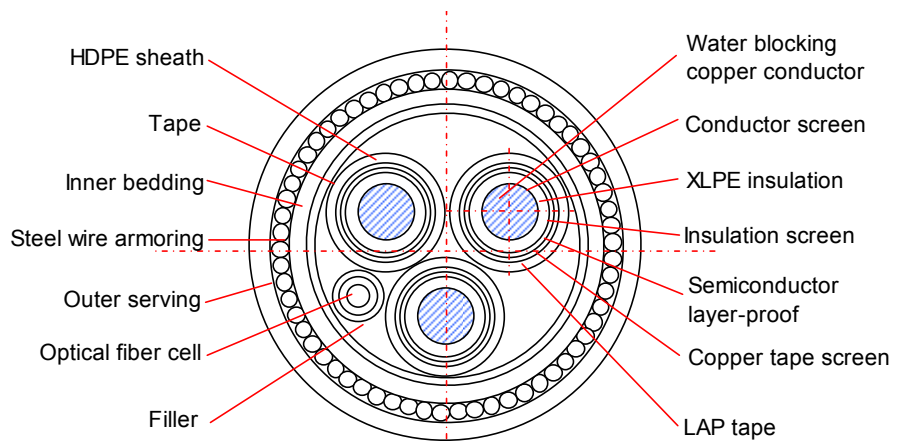

XLPE insulated separately LAP sheath submarine optical fiber/electric power composite cable

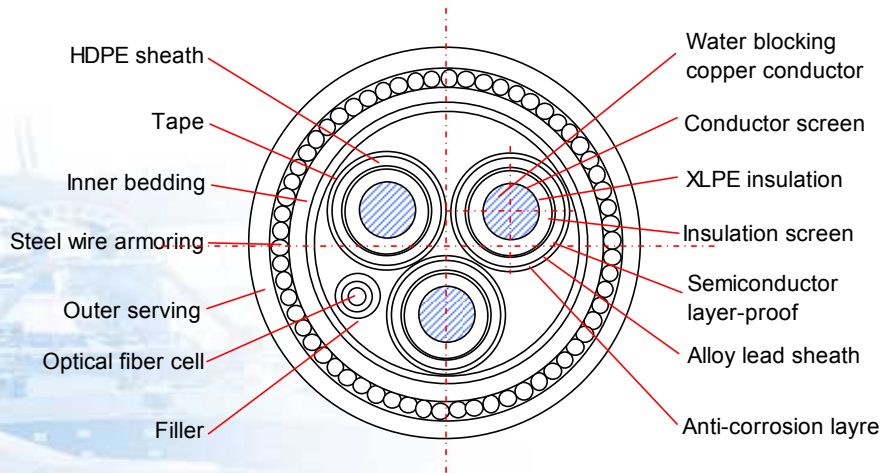

XLPE insulated separately lead sheath submarine optical fiber/electric power composite cable

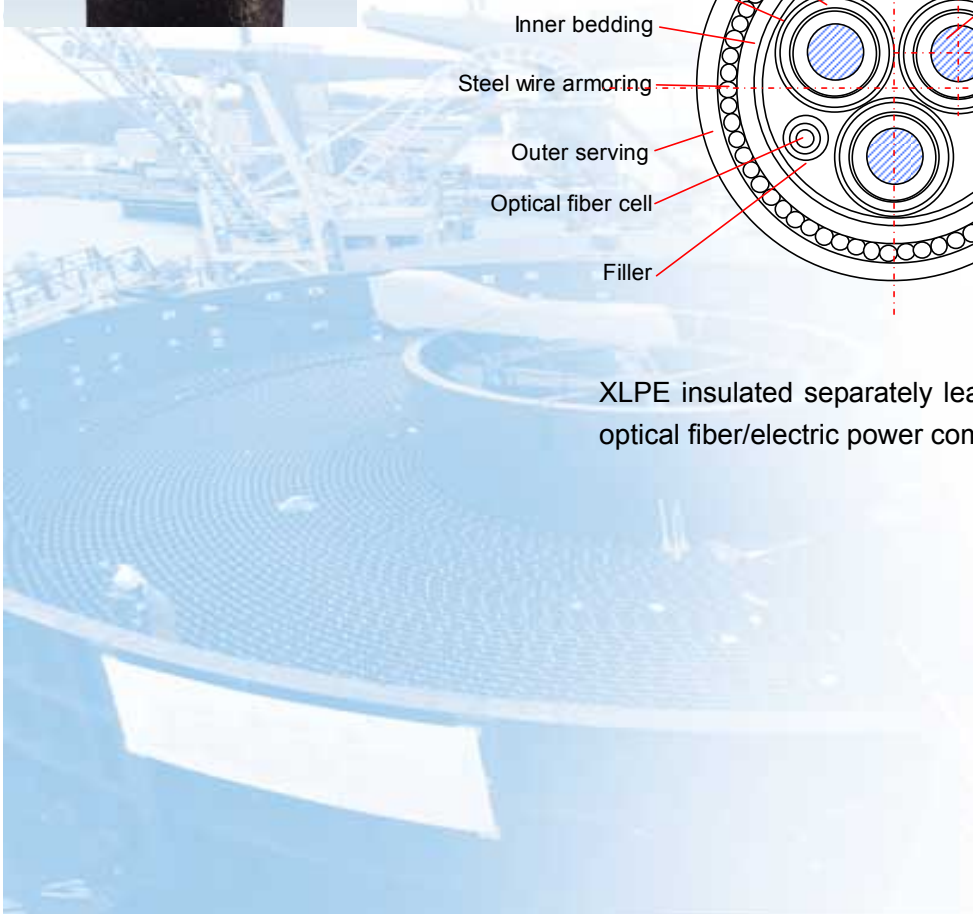

# Structure diameter of Submarine Optical Fiber cable and Submarine Optical Fiber

## Compound Power Cable

Rated voltage: 6/6kV, 6/10kV (ZS-YJQF41, ZS-YJQF41+OFC)

cross section	Conductor diameter	Insulation diameter	Lead sheath thickness	HDPE thickness	Bedding thickness	Armoring steel wire dia.	Bedding thickness	Appr. Cable dia.	Appr. Cable Weight	Appr. Cable dia.**	Appr. Cable Weight**
mm <sup>2</sup>	mm	mm	mm	mm	mm	mm	mm	mm	Kg/m	mm	Kg/m
50	8.2	3.4	1.5	2.1	2.0	5.0	4.0	76	14.5	83	16.0
70	10.0	3.4	1.6	2.1	2.0	5.0	4.0	80	16.2	87	18.0
95	11.6	3.4	1.6	2.2	2.0	5.0	4.0	83	18.0	91	19.8
120	13.0	3.4	1.7	2.2	2.0	5.0	4.0	87	19.7	94	21.6
150	14.6	3.4	1.7	2.2	2.0	5.0	4.0	90	21.7	98	23.5
185	16.2	3.4	1.8	2.3	2.0	5.0	4.0	94	23.8	102	25.7
240	18.4	3.4	1.8	2.3	2.0	5.0	4.0	99	27.1	107	29.3
300	20.6	3.4	1.9	2.4	2.0	5.0	4.0	104	30.5	112	32.7
400	23.8	3.4	2.0	2.4	2.0	5.0	4.0	111	35.0	120	37.7

Rated voltage: 8.7/10kV, 8.7/15kV (ZS-YJQF41, ZS-YJQF41+OFC)

Cross section	Conductor diameter	Insulation diameter	Lead sheath thickness	HDPE thickness	Bedding thickness	Armoring steel wire dia.	Bedding thickness	Appr. Cable dia.	Appr. Cable Weight	Appr. Cable dia.**	Appr. Cable Weight**
mm <sup>2</sup>	mm	mm	mm	mm	mm	mm	mm	mm	Kg/m	mm	Kg/m
50	8.2	4.5	1.6	2.2	2.0	5.0	4.0	81	15.9	88	17.7
70	10.0	4.5	1.6	2.2	2.0	5.0	4.0	85	17.7	92	19.7
95	11.6	4.5	1.7	2.2	2.0	5.0	4.0	88	19.5	96	21.6
1200	13.0	4.5	1.7	2.3	2.0	5.0	4.0	92	21.2	99	23.4
150	14.6	4.5	1.8	2.3	2.0	5.0	4.0	95	23.3	103	25.4
185	16.2	4.5	1.8	2.3	2.0	5.0	4.0	99	25.5	107	27.8
240	18.4	4.5	1.9	2.4	2.0	5.0	4.0	104	28.8	112	31.3
300	20.6	4.5	1.9	2.4	2.0	5.0	4.0	109	32.2	117	34.8
400	23.8	4.5	2.0	2.5	2.0	5.0	4.0	116	37.1	125	40.1

### Rated voltage: 12/20kV (ZS-YJQF41, ZS-YJQF41+OFC)

Cross section	Conductor diameter	Insulation diameter	Lead sheath thickness	HDPE thickness	Bedding thickness	Armoring steel wire dia.	Bedding thickness	Appr. Cable dia.	Appr. Cable Weight	Appr. Cable dia.**	Appr. Cable Weight**
mm <sup>2</sup>	mm	mm	mm	mm	mm	mm	mm	mm	Kg/m	mm	Kg/m
50	8.2	5.5	1.7	2.2	2.0	5.0	4.0	85	17.5	93	19.4
70	10.0	5.5	1.7	2.2	2.0	5.0	4.0	89	19.3	97	21.4
95	11.6	5.5	1.8	2.3	2.0	5.0	4.0	93	21.1	101	23.4
120	13.0	5.5	1.8	2.3	2.0	5.0	4.0	96	22.9	104	25.2
150	14.6	5.5	1.8	2.3	2.0	5.0	4.0	100	24.9	108	37.2
185	16.2	5.5	1.9	2.4	2.0	5.0	4.0	104	27.1	112	29.6
240	18.4	5.5	1.9	2.4	2.0	5.0	4.0	109	20.7	114	33.2
300	20.6	5.5	2.0	2.5	2.0	5.0	4.0	114	34.1	122	36.9
400	23.8	5.5	2.1	2.5	2.0	5.0	4.0	121	39.1	129	42.0

Note: \*according to needs \*\*in accordance with\*, diameter and weight of cable having separate HDPE outer sheath

### Rated voltage: 18/30kV (ZS-YJQF41, ZS-YJQF41+OFC)

Cross section	Conductor diameter	Insulation diameter	Lead sheath thickness	HDPE thickness	Bedding thickness	Armoring steel wire dia.	Bedding thickness	Appr. Cable dia.	Appr. Cable Weight	Appr. Cable dia.**	Appr. Cable Weight**
mm <sup>2</sup>	mm	mm	mm	mm	mm	mm	mm	mm	Kg/m	mm	Kg/m
50	8.2	8.0	1.8	2.3	2.0	5.0	4.0	97	21.4	105	23.7
70	10.0	8.0	1.9	2.3	2.0	5.0	4.0	101	23.4	109	25.8
95	11.6	8.0	1.9	2.4	2.0	5.0	4.0	104	25.5	113	27.9
120	13.0	8.0	1.9	2.4	2.0	5.0	4.0	108	27.3	116	29.9
150	14.6	8.0	2.0	2.4	2.0	5.0	4.0	111	29.4	120	32.0
185	16.2	8.0	2.0	2.5	2.0	5.0	4.0	115	31.7	124	34.7
240	18.4	8.0	2.1	2.5	2.0	5.0	4.0	120	35.3	129	38.4
300	20.6	8.0	2.2	2.6	2.0	5.0	4.0	125	38.9	134	42.1
400	23.8	8.0	2.2	2.6	2.0	5.0	4.0	132	44.3	142	47.6

**Rated voltage: 21/35kV (ZS-YJQF41, ZS-YJQF41+OFC)**

Cross section	Conductor diameter	Insulation diameter	Lead sheath thickness	HDPE thickness	Bedding thickness	Armoring steel wire dia.	Bedding thickness	Appr. Cable dia.	Appr. Cable Weight	Appr. Cable dia.**	Appr. Cable Weight**
mm <sup>2</sup>	mm	mm	mm	mm	mm	mm	mm	mm	Kg/m	mm	Kg/m
50	8.2	93	1.9	2.3	2.0	5.0	4.0	103	23.7	111	26.1
70	10.0	93	1.9	2.3	2.0	5.0	4.0	107	25.7	115	28.4
95	11.6	93	2.0	2.4	2.0	5.0	4.0	111	27.9	119	30.5
120	13.0	93	2.0	2.4	2.0	5.0	4.0	114	29.8	122	32.6
150	14.6	93	2.1	2.4	2.0	5.0	4.0	117	31.9	126	34.7
185	16.2	93	2.1	2.5	2.0	5.0	4.0	121	34.4	130	37.3
240	18.4	93	2.2	2.5	2.0	5.0	4.0	126	38.0	135	41.2
300	20.6	93	2.2	2.6	2.0	5.0	4.0	131	41.7	140	45.1
400	23.8	93	2.3	2.6	2.0	5.0	4.0	138	47.1	148	50.6

**Rated voltage: 26/35kV (ZS-YJQF41, ZS-YJQF41+OFC)**

Cross section	Conductor diameter	Insulation diameter	Lead sheath thickness	HDPE thickness	Bedding thickness	Armoring steel wire dia.	Bedding thickness	Appr. Cable dia.	Appr. Cable Weight	Appr. Cable dia.**	Appr. Cable Weight**
mm <sup>2</sup>	mm	mm	mm	mm	mm	mm	mm	mm	Kg/m	mm	Kg/m
50	8.2	10.5	2.0	2.4	2.0	5.0	4.0	108	25.8	117	28.4
70	10.0	10.5	2.0	2.4	2.0	5.0	4.0	112	28.0	121	30.7
95	11.6	10.5	2.1	2.5	2.0	5.0	4.0	116	30.1	125	32.9
120	13.0	10.5	2.1	2.5	2.0	5.0	4.0	119	32.1	128	35.0
150	14.6	10.5	2.1	2.5	2.0	5.0	4.0	123	34.3	132	37.4
185	16.2	10.5	2.2	2.6	2.0	5.0	4.0	126	36.8	136	40.0
240	18.4	10.5	2.2	2.6	2.0	5.0	4.0	131	40.5	141	43.9
300	20.6	10.5	2.3	2.7	2.0	5.0	4.0	136	44.3	146	47.7
400	23.8	10.5	2.4	2.7	2.0	5.0	4.0	144	49.9	154	53.6

Note: \*according to needs \*\*in accordance with\*, diameter and weight of cable having separate HDPE outer sheath

**Rated voltage: 6/6kV, 6/10kV (ZS-YJAF41, ZS-YJAF41+OFC)**

Cross section	Conductor diameter	Insulation diameter	Lead sheath thickness	HDPE thickness	Bedding thickness	Armoring steel wire dia.	Bedding thickness	Appr. Cable dia.	Appr. Cable Weight
mm <sup>2</sup>	mm	mm	mm	mm	mm	mm	mm	mm	Kg/m
50	8.2	3.4	0.3	2.6	2.0	5.0	4.0	83	13.0
70	10.0	3.4	0.3	2.6	2.0	5.0	4.0	87	14.6
95	11.6	3.4	0.3	2.6	2.0	5.0	4.0	91	16.0
120	13.0	3.4	0.3	2.6	2.0	5.0	4.0	94	17.4
150	14.6	3.4	0.3	2.7	2.0	5.0	4.0	97	18.9
185	16.2	3.4	0.3	2.7	2.0	5.0	4.0	101	20.7
240	18.4	3.4	0.3	2.8	2.0	5.0	4.0	106	23.4
300	20.6	3.4	0.3	2.8	2.0	5.0	4.0	111	26.3
400	23.8	3.4	0.3	2.9	2.0	5.0	4.0	118	30.2

**Rated voltage: 8.7/10kV, 8.7/15kV (ZS-YJAF41, ZS-YJAF41+OFC)**

Cross section	Conductor diameter	Insulation diameter	Lead sheath thickness	HDPE thickness	Bedding thickness	Armoring steel wire dia.	Bedding thickness	Appr. Cable dia.	Appr. Cable Weight
mm <sup>2</sup>	mm	mm	mm	mm	mm	mm	mm	mm	Kg/m
50	8.2	4.5	0.3	2.6	2.0	5.0	4.0	88	14.2
70	10.0	4.5	0.3	2.6	2.0	5.0	4.0	92	15.6
95	11.6	4.5	0.3	2.6	2.0	5.0	4.0	95	17.3
120	13.0	4.5	0.3	2.6	2.0	5.0	4.0	99	18.7
150	14.6	4.5	0.3	2.7	2.0	5.0	4.0	102	20.3
185	16.2	4.5	0.3	2.7	2.0	5.0	4.0	106	22.1
240	18.4	4.5	0.3	2.8	2.0	5.0	4.0	111	24.9
300	20.6	4.5	0.3	2.8	2.0	5.0	4.0	116	27.8
400	23.8	4.5	0.3	2.9	2.0	5.0	4.0	123	31.8

**Rated voltage: 12/20kV (ZS-YJAF41, ZS-YJAF41+OFC)**

Cross section	Conductor diameter	Insulation diameter	Lead sheath thickness	HDPE thickness	Bedding thickness	Armoring steel wire dia.	Bedding thickness	Appr. Cable dia.	Appr. Cable Weight
mm <sup>2</sup>	mm	mm	mm	mm	mm	mm	mm	mm	Kg/m
50	8.2	5.5	0.3	2.6	2.0	5.0	4.0	92	15.3
70	10.0	5.5	0.3	2.7	2.0	5.0	4.0	96	16.7
95	11.6	5.5	0.3	2.7	2.0	5.0	4.0	100	18.3
120	13.0	5.5	0.3	2.7	2.0	5.0	4.0	103	19.7
150	14.6	5.5	0.3	2.8	2.0	5.0	4.0	107	21.3
185	16.2	5.5	0.3	2.8	2.0	5.0	4.0	110	23.3
240	18.4	5.5	0.3	2.8	2.0	5.0	4.0	115	26.1
300	20.6	5.5	0.3	2.9	2.0	5.0	4.0	120	29.0
400	23.8	5.5	0.3	2.9	2.0	5.0	4.0	127	33.1

**Rated voltage: 18/30kV (ZS-YJAF41, ZS-YJAF41+OFC)**

Cross section	Conductor diameter	Insulation diameter	Lead sheath thickness	HDPE thickness	Bedding thickness	Armoring steel wire dia.	Bedding thickness	Appr. Cable dia.	Appr. Cable Weight
mm <sup>2</sup>	mm	mm	mm	mm	mm	mm	mm	mm	Kg/m
50	8.2	8.0	0.3	2.7	2.0	5.0	4.0	104	18.2
70	10.0	8.0	0.3	2.8	2.0	5.0	4.0	108	19.8
95	11.6	8.0	0.3	2.8	2.0	5.0	4.0	111	21.4
120	13.0	8.0	0.3	2.8	2.0	5.0	4.0	114	22.9
150	14.6	8.0	0.3	2.9	2.0	5.0	4.0	118	24.5
185	16.2	8.0	0.3	2.9	2.0	5.0	4.0	121	26.4
240	18.4	8.0	0.3	2.9	2.0	5.0	4.0	126	29.4
300	20.6	8.0	0.3	3.0	2.0	5.0	4.0	131	32.3
400	23.8	8.0	0.3	3.0	2.0	5.0	4.0	138	36.7

**Rated voltage: 21/35kV (ZS-YJAF41, ZS-YJAF41+OFC)**

Cross section	Conductor diameter	Insulation diameter	Lead sheath thickness	HDPE thickness	Bedding thickness	Armoring steel wire dia.	Bedding thickness	Appr. Cable dia.	Appr. Cable Weight
mm <sup>2</sup>	mm	mm	mm	mm	mm	mm	mm	mm	Kg/m
50	8.2	9.3	0.3	2.8	2.0	5.0	4.0	109	19.8
70	10.0	9.3	0.3	2.8	2.0	5.0	4.0	113	21.3
95	11.6	9.3	0.3	2.9	2.0	5.0	4.0	117	23.1
120	13.0	9.3	0.3	2.9	2.0	5.0	4.0	120	24.7
150	14.6	9.3	0.3	2.9	2.0	5.0	4.0	124	26.3
185	16.2	9.3	0.3	2.9	2.0	5.0	4.0	127	28.3
240	18.4	9.3	0.3	3.0	2.0	5.0	4.0	132	31.3
300	20.6	9.3	0.3	3.0	2.0	5.0	4.0	137	34.3
400	23.8	9.3	0.3	3.1	2.0	5.0	4.0	144	38.6

**Rated voltage: 26/35kV (ZS-YJAF41, ZS-YJAF41+OFC)**

Cross section	Conductor diameter	Insulation diameter	Lead sheath thickness	HDPE thickness	Bedding thickness	Armoring steel wire dia.	Bedding thickness	Appr. Cable dia.	Appr. Cable Weight
mm <sup>2</sup>	mm	mm	mm	mm	mm	mm	mm	mm	Kg/m
50	8.2	10.5	0.3	2.8	2.0	5.0	4.0	115	21.4
70	10.0	10.5	0.3	2.9	2.0	5.0	4.0	119	23.1
95	11.6	10.5	0.3	2.9	2.0	5.0	4.0	122	24.8
120	13.0	10.5	0.3	2.9	2.0	5.0	4.0	126	16.4
150	14.6	10.5	0.3	3.0	2.0	5.0	4.0	129	28.1
185	16.2	10.5	0.3	3.0	2.0	5.0	4.0	133	30.1
240	18.4	10.5	0.3	3.0	2.0	5.0	4.0	138	33.1
300	20.6	10.5	0.3	3.1	2.0	5.0	4.0	142	35.8
400	23.8	10.5	0.3	3.1	2.0	5.0	4.0	150	40.8

## Performance parameter of Submarine Optical Fiber Cable and Submarine Optical Fiber Compound Power Cable

Rated voltage: 6/6kV, 6/10kV (ZS-YJQF41, ZS-YJQF41+OFC)

Nominal cross section	Screen Cross section	DC20℃ Conductor resistance	DC90℃ Conductor resistance	DC20℃ Screen resistance	Capacitance	Inductance	Ampacity		1 s Short circuit current	
							Ampacity	Earth	Conductor	screen
mm <sup>2</sup>	mm <sup>2</sup>	Ω/km	Ω/km	Ω/km	μF/km	m H/km	A	A	kA	kA
50	100.8	0.387	0.494	2.12	0.263	0.417	199	197	7.2	2.3
70	117.1	0.268	0.342	1.83	0.301	0.383	247	240	10.0	2.5
95	125.2	0.193	0.246	1.71	0.334	0.365	297	285	13.6	2.9
120	141.0	0.153	0.196	1.52	0.363	0.353	338	321	17.2	3.0
150	149.5	0.124	0.159	1.43	0.396	0.340	381	357	21.5	3.4
185	167.9	0.0991	0.127	1.27	0.429	0.330	431	398	26.5	3.5
240	180.4	0.0754	0.0970	1.19	0.475	0.317	499	453	34.3	4.0
300	204.1	0.0601	0.0778	1.05	0.520	0.307	562	502	42.9	4.3
400	235.6	0.0470	0.0614	0.908	0.585	0.296	640	559	57.2	4.6

Rated voltage: 8.7/10kV, 8.7/15kV (ZS-YJQF41, ZS-YJQF41+OFC)

Nominal cross section	Screen Cross section	DC20℃ Conductor resistance	DC90℃ Conductor resistance	DC20℃ Screen resistance	Capacitance	Inductance	Ampacity		1 s Short circuit current	
							Ampacity	Earth	Conductor	screen
mm <sup>2</sup>	mm <sup>2</sup>	Ω/km	Ω/km	Ω/km	μF/km	m H/km	A	A	kA	kA
50	119.1	0.387	0.494	1.80	0.213	0.435	201	198	7.2	2.3
70	128.2	0.268	0.342	1.067	0.242	0.401	249	241	10.0	2.5
95	145.3	0.193	0.246	1.47	0.267	0.383	299	285	13.6	2.9
120	152.7	0.153	0.196	1.40	0.289	0.370	340	321	17.2	3.0
150	171.3	0.124	0.159	1.25	0.314	0.354	383	356	21.5	3.4
185	180.4	0.0991	0.127	1.19	0.339	0.343	433	397	26.5	3.5
240	204.1	0.0754	0.0970	1.05	0.374	0.330	495	449	34.3	4.0
300	217.3	0.0601	0.0778	0.985	0.408	0.319	564	500	42.9	4.3
400	249.4	0.0470	0.0614	0.858	0.458	0.307	642	557	57.2	4.9

**Rated voltage: 12/20kV (ZS-YJQF41, ZS-YJQF41+OFC)**

Nominal cross section	Screen Cross section	DC20°C Conductor resistance	DC90°C Conductor resistance	DC20°C Screen resistance	Capacitance	Inductance	Ampacity		1 s Short circuit current	
							Ampacity	Earth	Conductor	screen
mm <sup>2</sup>	mm <sup>2</sup>	Ω/km	Ω/km	Ω/km	μF/km	m H/km	A	A	kA	kA
50	137.8	0.387	0.494	1.55	0.185	0.450	202	197	7.2	2.7
70	147.4	0.268	0.342	1.45	1.45	0.415	249	239	10.0	2.9
95	165.7	0.193	0.264	1.29	1.29	0.396	299	283	13.6	3.3
120	173.6	0.153	0.196	1.23	1.23	0.383	341	319	17.2	3.4
150	182.7	0.124	0.159	1.17	1.17	0.367	384	355	21.5	3.6
185	202.9	0.0991	0.127	1.05	1.05	0.356	433	395	26.5	4.0
240	216.1	0.0754	0.0970	0.990	0.990	0.341	501	449	34.3	4.2
300	241.9	0.0601	0.0778	0.885	0.885	0.330	563	496	42.9	4.8
400	275.8	0.0470	0.0614	0.776	0.776	0.217	640	552	57.2	5.4

Lead sleeve screen, single circuit, conductor operating temp. =90°C, earth temp. =25°C, earth temp. resistance =1.0K.m/w, burying depth 1.5m, air temp. =45°C.

**Rated voltage: 18/30kV (ZS-YJQF41, ZS-YJQF41+OFC)**

Nominal cross section	Screen Cross section	DC20°C Conductor resistance	DC90°C Conductor resistance	DC20°C Screen resistance	Capacitance	Inductance	Ampacity		1 s Short circuit current	
							Ampacity	Earth	Conductor	screen
mm <sup>2</sup>	mm <sup>2</sup>	Ω/km	Ω/km	Ω/km	μF/km	m H/km	A	A	kA	kA
50	174.7	0.387	0.494	1.225	0.143	0.485	204	196	7.2	3.9
70	195.8	0.268	0.342	1.09	0.160	0.447	251	238	10.0	4.2
95	205.3	0.193	0.246	1.04	0.175	0.427	301	281	13.6	4.6
120	213.7	0.153	0.196	1.00	0.188	0.410	342	316	17.2	4.8
150	235.6	0.124	0.159	0.908	0.202	0.395	385	351	21.5	5.2
185	245.7	0.0991	0.127	0.871	0.217	0.383	434	391	26.5	5.4
240	273.1	0.0754	0.0970	0.783	0.236	0.367	500	448	34.3	6.0
300	302.0	0.0601	0.0788	0.708	0.256	0.354	561	488	42.9	6.3
400	324.1	0.0470	0.0614	0.660	0.284	0.339	641	545	57.2	6.4

**Rated voltage: 21/35kV (ZS-YJQF41, ZS-YJQF41+OFC)**

Nominal cross section	Screen Cross section	DC20°C Conductor resistance	DC90°C Conductor resistance	DC20°C Screen resistance	Capacitance	Inductance	Ampacity		1 s Short circuit current	
							Ampacity	Earth	Conductor	screen
mm <sup>2</sup>	mm <sup>2</sup>	Ω/km	Ω/km	Ω/km	μF/km	m H/km	A	A	kA	kA
50	200.6	0.387	0.494	1.07	0.130	0.501	207	198	7.2	3.9
70	211.3	0.268	0.342	0.01	0.145	0.463	254	240	10.0	4.2
95	233.1	0.193	0.246	0.918	0.158	0.442	304	282	13.6	4.6
120	241.9	0.153	0.196	0.885	0.169	0.423	345	317	17.2	4.8
150	265.2	0.124	0.159	0.807	0.182	0.408	387	351	21.5	5.2
185	275.8	0.0991	0.127	0.776	0.194	0.395	431	388	26.5	5.4
240	304.8	0.0754	0.0970	0.702	0.211	0.378	501	450	34.3	6.0
300	320.0	0.0601	0.0778	0.669	0.228	0.366	563	488	42.9	6.3
400	358.4	0.0470	0.0614	0.597	0.253	0.350	641	542	57.2	7.0

**Rated voltage: 26/35kV (ZS-YJQF41, ZS-YJQF41+OFC)**

Nominal cross section	Screen Cross section	DC20°C Conductor resistance	DC90°C Conductor resistance	DC20°C Screen resistance	Capacitance	Inductance	Ampacity		1 s Short circuit current	
							Ampacity	Earth	Conductor	screen
mm <sup>2</sup>	mm <sup>2</sup>	Ω/km	Ω/km	Ω/km	μF/km	m H/km	A	A	kA	kA
50	226.8	0.387	0.494	0.943	0.121	0.514	207	197	7.2	4.5
70	238.1	0.268	0.342	0.899	0.134	0.475	255	239	10.0	4.7
95	261.3	0.193	0.246	0.819	0.146	0.454	304	281	13.6	5.1
120	270.5	0.153	0.196	0.791	0.156	0.435	345	315	17.2	5.3
150	281.0	0.124	0.159	0.761	0.167	0.420	388	350	21.5	5.5
185	306.2	0.0991	0.127	0.699	0.178	0.406	435	388	26.5	6.0
240	321.4	0.0754	0.0970	0.666	0.193	0.389	501	450	34.3	6.3
300	352.6	0.0601	0.0778	0.607	0.209	0.375	561	484	42.9	6.9
400	392.8	0.0470	0.0614	0.545	0.230	0.359	638	537	57.2	7.7

Lead sleeve screen, single circuit, conductor operating temp. =90°C, earth temp. =25°C, earth temp. Resistance =1.0K.m/w, burying depth 1.5m, air temp. =45°C.

**Rated voltage: 6/6kV, 6/10kV (ZS-YJAF41, ZS-YJAF41+OFC)**

Nominal cross section	Screen Cross section	DC20°C Conductor resistance	DC90°C Conductor resistance	DC20°C Screen resistance	Capacitance	Inductance	Ampacity		1 s Short circuit current	
							Ampacity	Earth	Conductor	screen
mm <sup>2</sup>	mm <sup>2</sup>	Ω/km	Ω/km	Ω/km	μF/km	m H/km	A	A	kA	kA
50	3.0	0.387	0.494	5.75	0.263	0.444	194	193	7.2	0.3
70	3.0	0.268	0.342	5.75	0.301	0.408	241	236	10.0	0.3
95	3.0	0.193	0.246	5.75	0.334	0.388	290	280	13.6	0.3
120	3.0	0.153	0.196	5.75	0.363	0.373	331	316	17.2	0.3
150	3.0	0.124	0.159	5.75	0.396	0.360	373	353	21.5	0.3
185	3.0	0.0991	0.127	5.75	0.429	0.348	423	396	26.5	0.3
240	4.0	0.0754	0.0970	4.31	0.475	0.334	491	452	34.3	0.4
300	4.0	0.0601	0.0778	4.31	0.520	0.323	555	503	42.9	0.4
400	4.0	0.0470	0.0614	4.31	0.585	0.310	637	564	57.2	0.4

**Rated voltage: 8.7/10kV,8.7/15kV (ZS-YJAF41, ZS-YJAF41+OFC)**

Nominal cross section	Screen Cross section	DC20°C Conductor resistance	DC90°C Conductor resistance	DC20°C Screen resistance	Capacitance	Inductance	Ampacity		1 s Short circuit current	
							Ampacity	Earth	Conductor	screen
mm <sup>2</sup>	mm <sup>2</sup>	Ω/km	Ω/km	Ω/km	μF/km	m H/km	A	A	kA	kA
50	3.0	0.387	0.494	5.75	0.213	0.459	196	164	7.2	0.0
70	3.0	0.268	0.342	5.75	0.242	0.423	243	236	10.0	0.3
95	3.0	0.193	0.246	5.75	0.267	0.403	292	281	13.6	0.3
120	3.0	0.153	0.196	5.75	0.289	0.387	333	317	17.2	0.3
150	3.0	0.124	0.159	5.75	0.314	0.373	376	354	21.5	0.4
185	4.0	0.0991	0.127	4.31	0.339	0.361	426	396	26.5	0.4
240	4.0	0.0754	0.0970	4.31	0.374	0.346	494	452	34.3	0.4
300	4.0	0.0601	0.0778	4.31	0.408	0.335	558	503	42.9	0.4
400	4.0	0.0470	0.0614	4.31	0.458	0.321	640	564	57.2	0.4

### Rated voltage: 12 /20kV (ZS-YJAF41, ZS-YJAF41+OFC)

Nominal cross section	Screen Cross section	DC20°C Conductor resistance	DC90°C Conductor resistance	DC20°C Screen resistance	Capacitance	Inductance	Ampacity		1 s Short circuit current	
							Ampacity	Earth	Conductor	screen
mm <sup>2</sup>	mm <sup>2</sup>	Ω/km	Ω/km	Ω/km	μF/km	m H/km	A	A	kA	kA
50	3.0	0.387	0.494	5.75	0.185	0.472	198	194	7.2	0.3
70	3.0	0.268	0.342	5.75	0.208	0.435	244	236	10.0	0.3
95	3.0	0.193	0.246	5.75	0.229	0.416	294	281	13.6	0.3
120	4.0	0.153	0.196	4.31	0.247	0.399	334	317	17.2	0.4
150	4.0	0.124	0.159	4.31	0.268	0.384	384	355	21.5	0.4
185	4.0	0.0991	0.127	4.31	0.289	0.3774	427	395	26.5	0.4
240	4.0	0.0754	0.0970	4.31	0.317	0.353	496	452	34.3	0.4
300	4.0	0.0601	0.0778	4.31	0.345	0.344	561	503	42.9	0.4
400	4.0	0.0470	0.0614	4.31	0.386	0.330	642	564	57.2	0.4

Lead sleeve screen, single circuit, conductor operating temp. =90°C, earth temp. =25°C, earth temp. resistance =1.0K.m/w, burying depth 1.5m, air temp. =45°C.

### Rated voltage: 18/30kV (ZS-YJAF41, ZS-YJAF41+OFC)

Nominal cross section	Screen Cross section	DC20°C Conductor resistance	DC90°C Conductor resistance	DC20°C Screen resistance	Capacitance	Inductance	Ampacity		1 s Short circuit current	
							Ampacity	Earth	Conductor	screen
mm <sup>2</sup>	mm <sup>2</sup>	Ω/km	Ω/km	Ω/km	μF/km	m H/km	A	A	kA	kA
50	4.0	0.387	0.494	4.31	0.143	0.503	200	195	7.2	0.4
70	4.0	0.268	0.342	4.31	0.160	0.464	248	236	10.0	0.4
95	4.0	0.193	0.246	4.31	0.175	0.443	297	281	13.6	0.4
120	4.0	0.153	0.196	4.31	0.188	0.425	338	317	17.2	0.4
150	4.0	0.124	0.159	4.31	0.202	0.409	385	351	21.5	0.4
185	4.0	0.0991	0.127	4.31	0.217	0.396	432	395	26.5	0.4
240	4.0	0.0754	0.0970	4.31	0.236	0.379	502	452	34.3	0.4
300	4.0	0.0601	0.0778	4.31	0.256	0.366	566	503	42.9	0.4
400	4.0	0.0470	0.0614	4.31	0.284	0.350	647	563	57.2	0.4

**Rated voltage: 21/35kV (ZS-YJAF41, ZS-YJAF41+OFC)**

Nominal cross section	Screen Cross section	DC20°C Conductor resistance	DC90°C Conductor resistance	DC20°C Screen resistance	Capacitance	Inductance	Ampacity		1 s Short circuit current	
							Ampacity	Earth	Conductor	screen
mm <sup>2</sup>	mm <sup>2</sup>	Ω/km	Ω/km	Ω/km	μF/km	m H/km	A	A	kA	kA
50	4.0	0.387	0.494	4.31	0.130	0.504	202	196	7.2	0.4
70	4.0	0.268	0.342	4.31	0.145	0.478	250	236	10.0	0.4
95	4.0	0.193	0.246	4.31	0.158	0.456	300	283	13.6	0.4
120	4.0	0.153	0.196	4.31	0.169	0.438	341	319	17.2	0.4
150	4.0	0.124	0.159	4.31	0.182	0.422	385	351	21.5	0.4
185	4.0	0.0991	0.127	4.31	0.194	0.408	435	398	26.5	0.4
240	4.0	0.0754	0.0970	4.31	0.211	0.391	507	452	34.3	0.4
300	4.0	0.0601	0.0778	4.31	0.228	0.377	570	505	42.9	0.4
400	4.0	0.0470	0.0614	4.31	0.253	0.360	653	567	57.2	0.4

**Rated voltage: 26/35kV (ZS-YJAF41, ZS-YJAF41+OFC)**

Nominal cross section	Screen Cross section	DC20°C Conductor resistance	DC90°C Conductor resistance	DC20°C Screen resistance	Capacitance	Inductance	Ampacity		1 s Short circuit current	
							Ampacity	Earth	Conductor	screen
mm <sup>2</sup>	mm <sup>2</sup>	Ω/km	Ω/km	Ω/km	μF/km	m H/km	A	A	kA	kA
50	4.0	0.387	0.494	4.31	0.121	0.529	203	196	7.2	0.4
70	4.0	0.268	0.342	4.31	0.134	0.489	251	236	10.0	0.4
95	4.0	0.193	0.246	4.31	0.146	0.467	301	283	13.6	0.4
120	4.0	0.153	0.196	4.31	0.156	0.449	343	319	17.2	0.4
150	4.0	0.124	0.159	4.31	0.167	0.432	386	350	21.5	0.4
185	4.0	0.0991	0.127	4.31	0.178	0.418	437	398	26.5	0.4
240	4.0	0.0754	0.0970	4.31	0.193	0.400	509	452	34.3	0.4
300	4.0	0.0601	0.0778	4.31	0.209	0.386	573	506	42.9	0.4
400	4.0	0.0470	0.0614	4.31	0.230	0.369	655	567	57.2	0.4

Lead sleeve screen, single circuit, conductor operating temp. =90°C, earth temp. =25°C, earth temp. resistance =1.0K.m/w, burying depth 1.5m, air temp. =45°C.



## Water penetration test

### The purpose of the test

- To evaluate the water-blocking performance of the stainless steel tube core under water pressure.

### Sample

- The sample to be tested should be finished SOFC. The Sampling length should be not less than 1250m.

### Measurement set-up

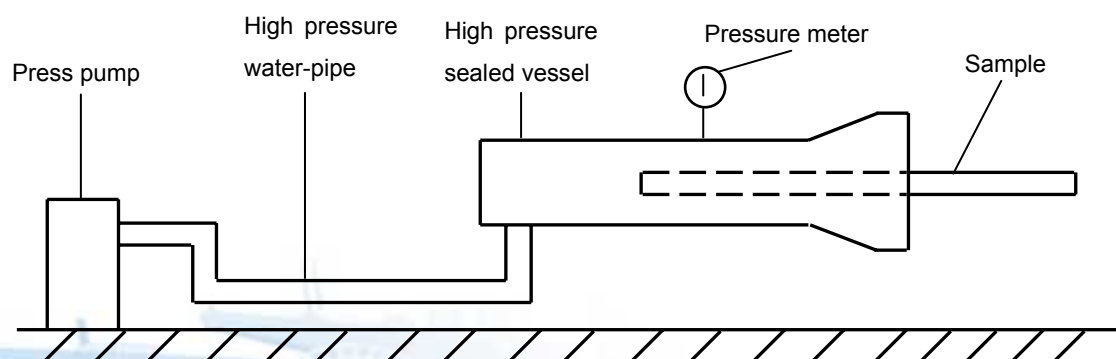

### Test Procedure

The one end of the cable sample is prepared to fully expose the core. This core end is then mounted into the termination device of the pressure vessel, and the protruding length should be not less than 1.0m. A 5.0MPa water pressure then be applied for 14 days. Effective sealing measures are required to ensure the water pressure to be applied directly at the exposed end. Some water soluble fluorescent dye should be added into the water to facilitate the detection of water penetration. The water penetration should be not more than 200m.

## Tensile load test procedure

### The purpose of the test

- It is to measure the attenuation variation of the fibers, the fiber and the elongation of the cable under specified tensile load.

### Sample

- The sample to be tested should be finished SOFC. The sampling length should be not less than 50m.

### Measurement set-up

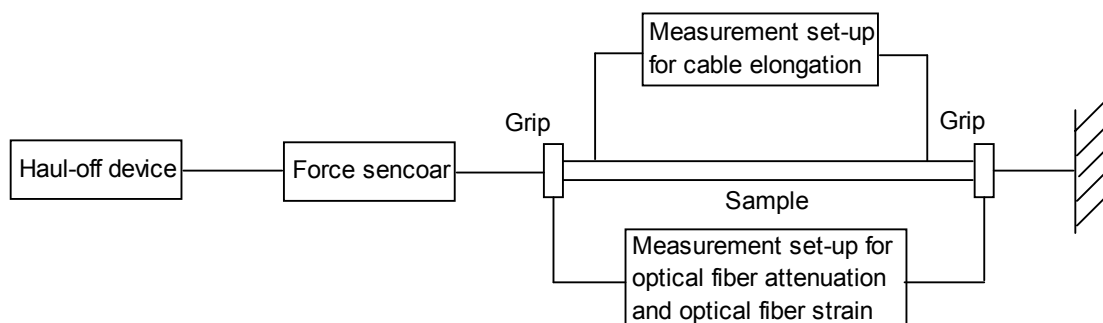

### Test procedure

The sample should be preconditioned at standard ambient conditions for 24 hour. As shown in the figure, the cable sample is mounted in the tensile device, proper length of both cable ends should be left. The output optical power is measured before applying tensile load.

A preload of 10kN should be applied before test, or a proper preload is applied to keep the sample straight. The language length  $L_1$  between two marks of the cable sample, which is mounted between two grips of the tensile device, is measured.

The load is applied as specified. The tensile load is applied continuously with the rate of 10mm/min-20mm/min up to the specified value, and maintained for at least 1 min. The output optical power and fiber strain are continuously measured during the test.

After the completion of the above procedure the tensile load is decreased to zero, and the output optical power and fiber strain of the sample are measured. Finally the residual strain of the fiber compared with the strain before load applied is calculated.

## Optical performance

Optical fiber type	Nominal operating wavelength	Attenuation	Attenuation equalization
(ITU-T G.652)	1310	≤0.36	≤0.05
	1550	≤0.25	≤0.03
(ITU-T G.655)	1550	≤0.22	≤0.03

## Testing reports from authoritative organization



Report issued by the  
Electronics No.23  
research Institute, MII.

Report issued by the Quality  
Inspection Center of Optical  
Communication Product, MII

Report issued by the  
Electronics No.8  
research Institute, MII. Report issued by  
Shanghai Electric Cable  
Research Institute

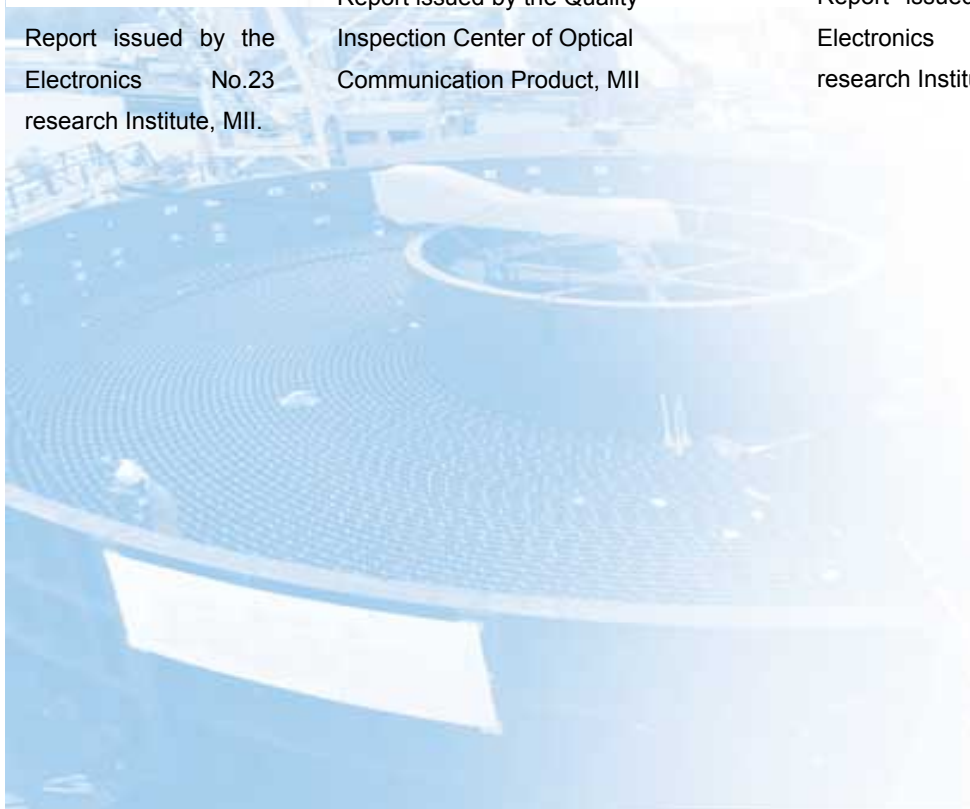

## Location advantage



### Location

- 90km far away Wusong kou from the Yangtze River mouth, Shanghai

### Hydrographic condition

- Broad river surface, weak tide and straight coast, the water depth in the outer side of the dock is more than 9m, and in the inner side, more than 6m

### Meteorological condition

- Annual average temperature is 15°C, not silting and freezing all the year

### Technological condition

- Double laser welding, in-line automatic tape butting, being able to produce long length of SOFC

### Test apparatus

- Providing with complete test apparatus for 50T tensile test, water penetration test under 5.0MPa etc.

# Construction

## Procedure

- Project application
- Sea trial for investigation and route selection
- Preparation for construction
- Construction carry-out
- Works acceptance

## Construction and laying of SOFC

The construction and laying of SOFC can use either direct laying or buried laying methods according to the sea-area condition.

- Direct laying---for sea depth more than 500m, the cable being laid directly on the sea-bed along predetermination route
- Buried laying ---for sea depth less than 5000m where is the epicontinental sea, the buried depth more than 1.5m being required.

Plough buried laying machine: suitable for short distance cable buried laying.

Water-jet buried laying machine: suitable for short distance cable buried laying in epicontinental sea area.

Self-propelled buried laying machine: suitable for the buried laying of the repairing cable section and

the joint for sectional cable laying.



Loading of SOFC



Confirmation of the construction plan



Conveyance of SOFC



Burial laying plough for SOFC

## Cable burying

In the shore side sea area, cables may get damaged caused by finishing gear attack and anchoring. Therefore cable should be buried in the shallow sea area to offer protection of cable.

- Gutter plough, used for long-haul laying.
- Water jet devices, used in shore side or shallow sea area.
- Engine plough, used for burying with recovery and joints.



## Landing operation

Landing operation is according to the distance between ship and landing site, terrain, water depth, water flow and gradient of the seaside environment.

- Float towing-suitable for shorter landing distance (less than 1000m), and the sea area where has smaller tide.
- Landing ship-suitable for longer distance (more than 1000m), and the sea area where has larger wave and current.



Construction



Landing



Landing

## Cable joints

Submarine cable joints complete with special tools and joint- box, generally it was done on the board. The operation need a skilled person to with rich experience. Sometimes it will take a long time according to the state of sea. It must be done by once.

- The operators have undergone the professional training and got the qualification of relative administration.
- Each progress should strictly accord with the operation requirement.
- Fiber joint should adopts the normal splicing method. All the procedure should be observed.
- The joint of the metal covering of the two joint ends should be designed as required. Joint and tension of the armor steel should be consistent to guarantee the endurance of tension at the joint.

ZTT's self –developed direct Joint-box, branch joint-box (patent product), sea-land joint-box etc. provide adequate and systematic service for cable construction.

## GJHQ submarine cable joint-box

- Apply to connection and maintenance of shallow sea cable.
- Directly joint-box and branch joint-box.



GJHQ-JT

- The shell was manufactured of specialized process with special material.
- Cone-shape locking craft used for the steel wire armoring.
- High mechanical strength, good sealing property and strong water corrosion resistance.



Type GJHQ-JF2

## GPJ-JA48 sea-side joint-box

- Apply to connection with overland cable after submarine cable landed.
- The shell was made of stainless steel with good quality.
- Cone-shape locking craft used for the steel wire armoring.
- High mechanical strength, good sealing property and strong water corrosion resistance.



## Visiting the SOFC base and acceptance of work



### ● Typical Customers of Zhongtian SOFC

-----Shanghai cable-network Co.

Crossing-river FOC project between Changxing Island and Hengsha Island, 400kN, 8 fibers.

-----Joint Venture between Radio & TV, Mobilecom and Unicom of Fuzhou City, Fujian Province.

SOFC Project between Fuqing and Pingtan Country, 400kN, 36 fibers.

-----China Netcom Co., Ltd.

Crossing-river FOC project of Yangtze River Estuary for APCN-2 extension section, 600kN, 48 fibers including 24 G.655 fibers.

-----Joint Venture between Zhejiang zhoushan broadcasting telecom, Unicom, mobile of zhejaing zhoushan. Zhoushan liuheng to ningbo guoju fiber optic cable hookup project.

730 cores (3 tubes) 54 cores (2 tubes) 64cores (2 tubes)

-----Yehai Railway Co., Ltd.

Yuehai Railway cross sea communication project

400kN, 48 cores

-----SOFC project of general Staff Communication department, Command of navy and naming area command communication department. The max. single cable is 53KM. The originated branch joint box of SOFC in China is put into sea application.